

User's Manual

Mold Protection Device PS-300B

[Miss feed Detector]



Table of contents

1. Overview of PS-300B
2. Functions of PS-300B
3. Function Descriptions
4. Diagram of PS-300B Sensor Installation
5. Press Emergency Stop Angle
6. How to Use PS-300B
7. Miss feed & Pass Detection Timing Settings
8. Wiring of Mic Jack Connector
9. PS-300B Wiring Diagram

1. Overview of PS-300B

This device is to protect mold and prevent defects by stopping Press before bottom dead center whenever detecting malfunctions of peripheral devices, mal-transfer, deflections of material by internal force in the mold, miss feed, overfeed, and product extraction, using various sensors at the time of Press operation. The device is expected to contribute to cost-reduction by enhanced productivity and decreased defects, because it allows for Press operation with fewer workers.

- ◆ 6-channel multi-function touch sensor detects oncoiler, material end and deflection(back-ring), miss feed, and over feed.
- ◆ Its Product Pass Detection Sensor monitors if products are properly extracted.
- ◆ It is compatible with a wide range of light sensors and Japanese sensor.

2. Functions of PS-300B

It protects mold and prevents defects through emergency stop function, when each of following problem occurs.

- ◆ In the event that materials are not uncoiled in Uncoiler.
- ◆ Depletion of material.
- ◆ Deflection of material between feeder and mold.
- ◆ In the even of errors in transfer pitch(miss feed and over feed)
- ◆ In the even that products are left not extracted and stays in the mold.

3. Function Descriptions

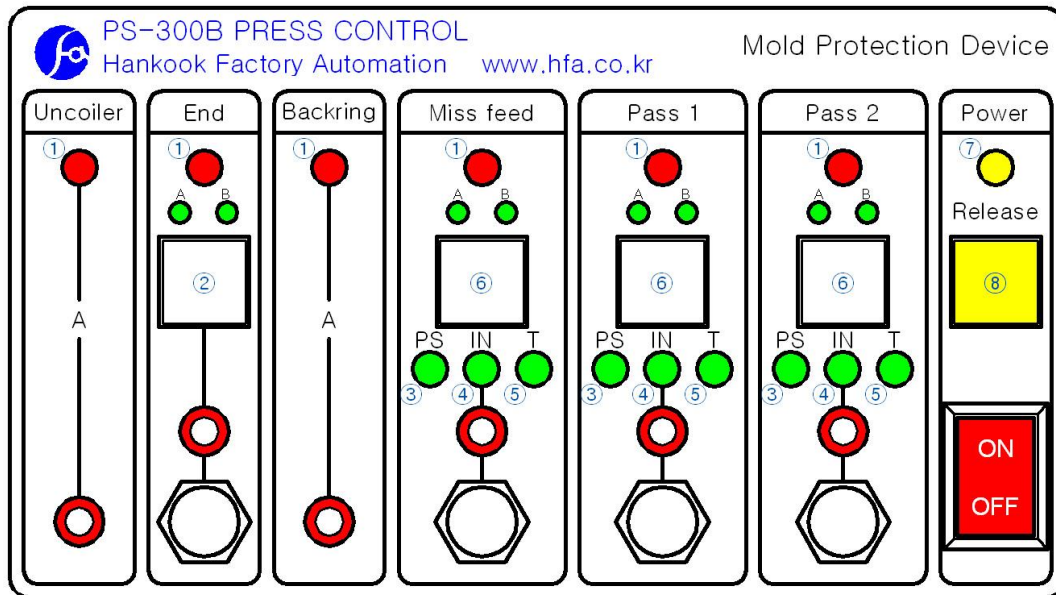

① **Emergency Stop Lamp** : lights in case of emergency stop of each part.

② **Button switch**: switch each time you press A, B, OFF is turned on sequentially.

A mode when a touch emergency stop,

B-mode emergency stop when a touch is a loss.

③ **PS Lamp(memory lamp)** : indicates sensor signal input.

④ **IN Lamp(input signal)** : lights in case of sensor signal input.

⑤ **T Lamp(miss feed, pass detection, synchronizing signal)**: lights in case of Rotary Cam fixed timing.

⑥ **Button switch** : Each time you press the switch A, B, OFF will light sequentially.

Miss feed, pass use A mode. Leave OFF when not in use.

⑦ **Power lamp**: indicates power on/off

⑧ **Release switch**: press for release of emergency stop.

4. Diagram of PS-300B Sensor Installation

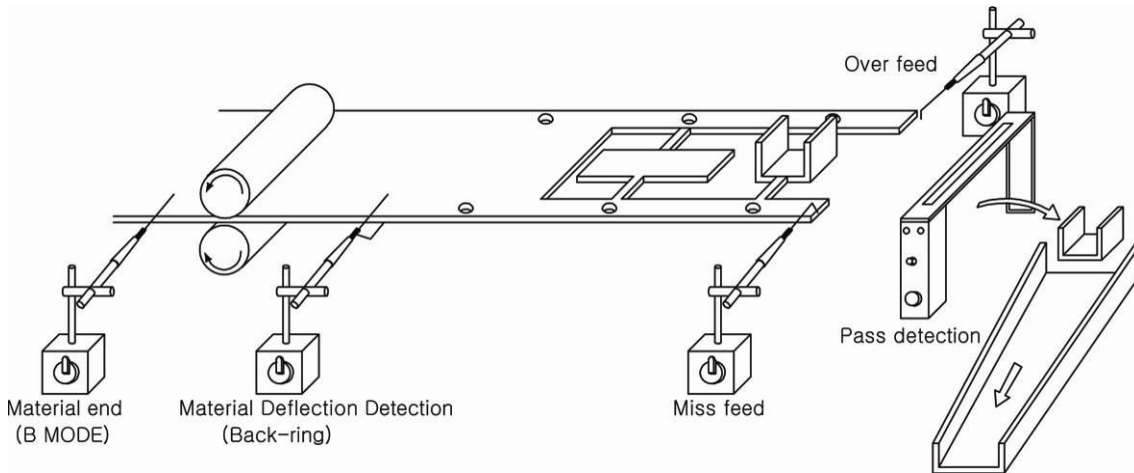

5. Press Emergency Stop Angle

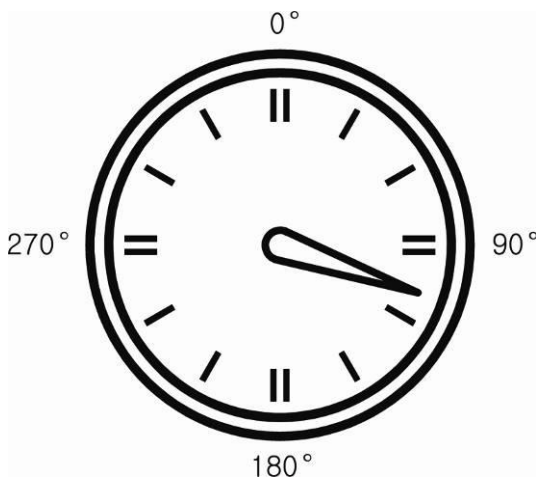

- ◆ In case of emergency stop, Press stops between 3 and 4 hours.
- ◆ Speed of stop angle depends on working speed of Press or brake capacity.
- ◆ Emergency stop by touch sensor happens immediately whenever sensor signal is on, regardless of time

6. How to Use PS-300B

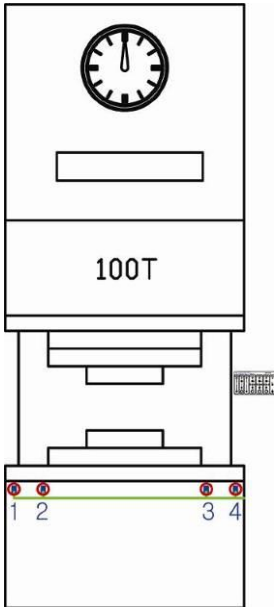

◆ Basic connection wiring of PS-300B refers to the picture on the left

- 1 : Material end
- 2 : Deflection of material
- 3 : Miss feed
- 4 : Pass detection 1

◆ Move and plug in connection cable in front of main body of PS-300B, if you want to use for other purposes than basic connection.

1) Uncoiler

- ◆ Install Touch Sensor on Uncoiler Control Bar.
- ◆ Press stops when uncoiled materials touch Control Bar.

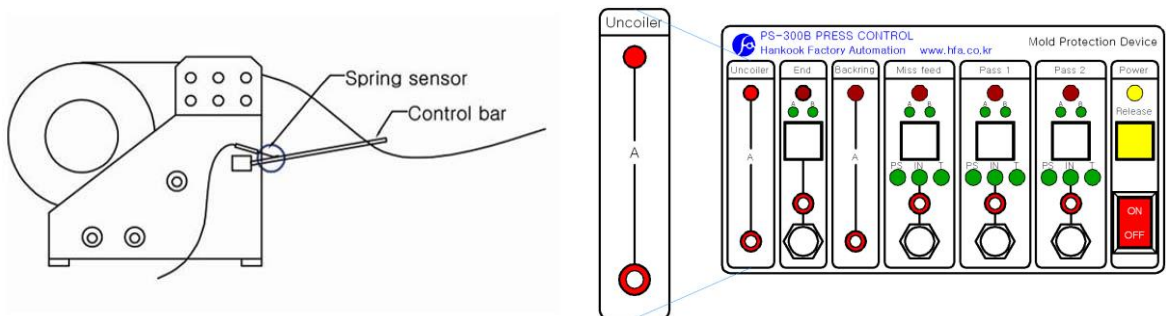

2) Material End

- ◆ Set material end selection switch to Mode B.
- ◆ In case of depletion of material in Touch Sensor, Press stops.
- ◆ Select the switch when not in use A, OFF mode, please.

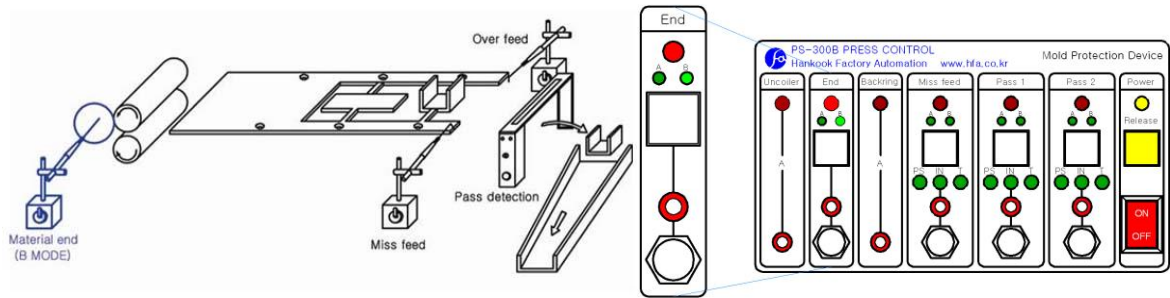

3) Material Deflection Detection(Back-ring)

- ◆ Fix Back-ring Touch Sensor in the material between Feeder and mold.
- ◆ In the event that deflected materials by internal force in the mold touch the sensor, stops occurs.

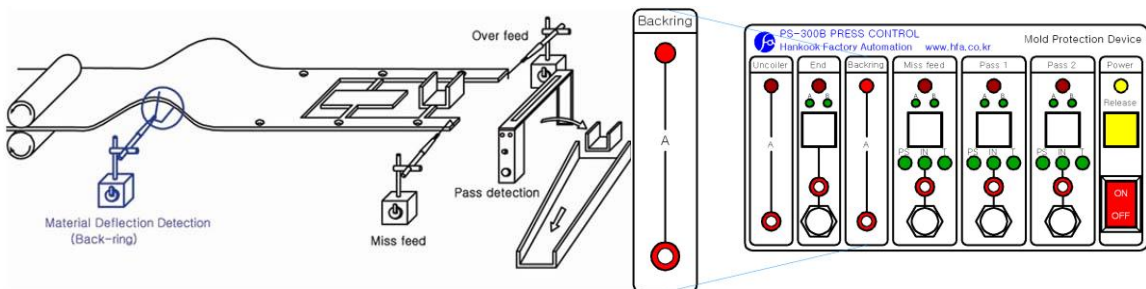

4) Miss feed

- ◆ Set miss feed selection switch to Mode A.
- ◆ Check if IN lamp lights whenever Spring Touch Sensor touches material.
- ◆ When not in use to select the mode to OFF. (A, B, OFF sequential lights)

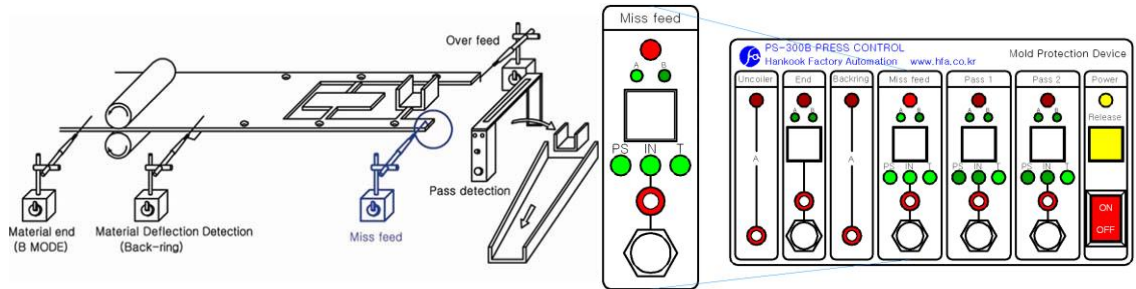

5) Over feed

- ◆ Set Pass 2 Selection Switch to Mode B.
- ◆ In the event of over feed during press operation, Press stops when declining from up dead center.
- ◆ When not in use to select the mode to OFF. (A, B, OFF sequential lights)

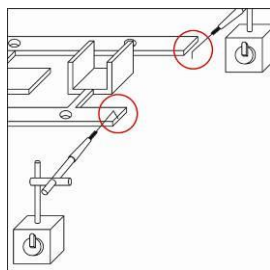
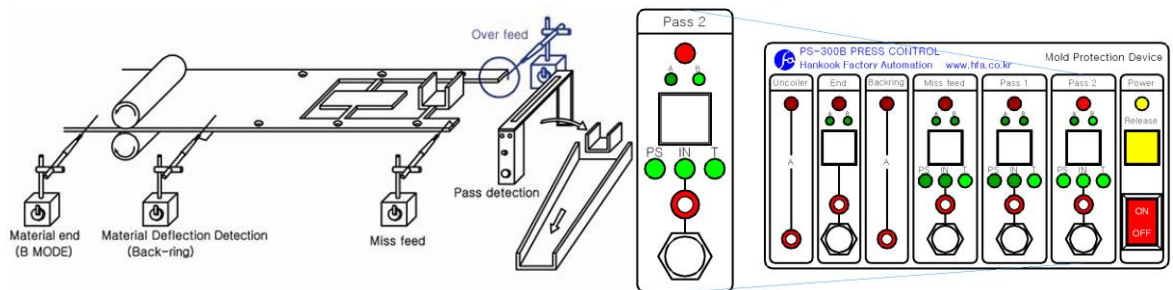

Spring Sensor detects miss feed and over feed

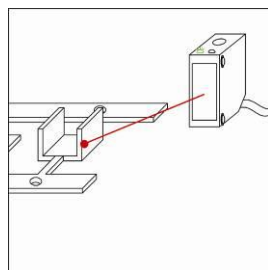

MS-20 Laser Sensor detects miss feed

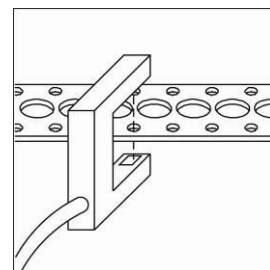

MS-50 Sensor detects miss feed (pilot hole)

6) Pass detection

- ◆ Set Pass Detection Selection Switch to Mode A.
- ◆ Check if IN lamp lights whenever materials pass.

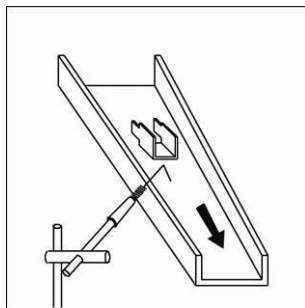
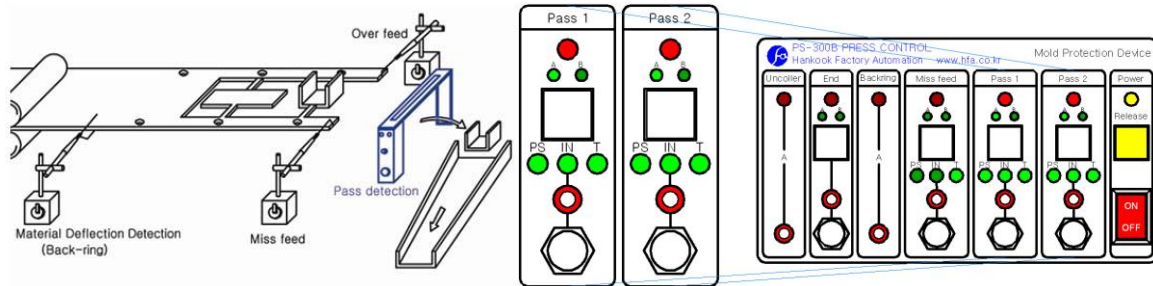

Spring Sensor
detects product pass

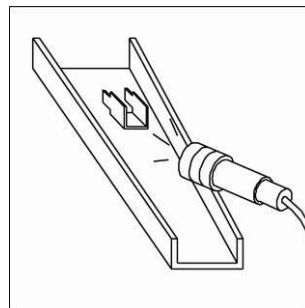

LS-300 Pass Sensor
detects product pass

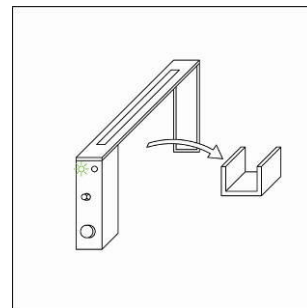

LS-350 Pass Sensor
detects product pass

- ◆ Product pass monitored from light-on of timing lamp (green T lamp) till light-off (1~2 hours).
If product pass speed is slow, adjust timing of Rotary Cam.
(See [7. Miss feed & Pass Detection Timing Settings](#))
- ◆ In case of using Spring Touch Sensor for pass detection, extracted products must touch suitor or mold. Otherwise, Spring Touch Sensor cannot detect products.
- ◆ Remove lights around LS-350 Pass Sensor. They may cause malfunction.
- ◆ Turn Selection Switch to OFF in the middle when not used.

7. Miss feed & Pass Detection Timing Settings

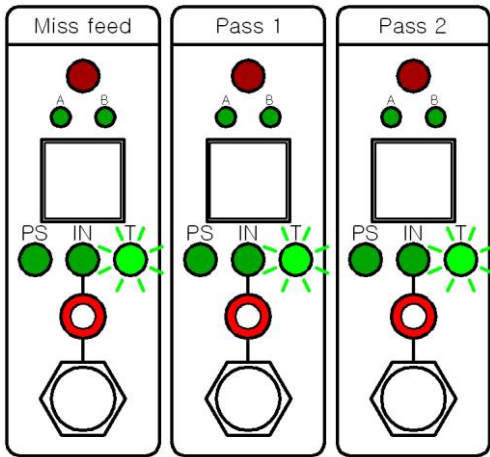

- ◆ Adjust lighting timing of miss feed and pass detection T lamp on the front of PS-300B
- ◆ You may adjust so that wrong timing setting can be corrected or press operation condition can be optimized.

1) Rotary Cam Timing Settings

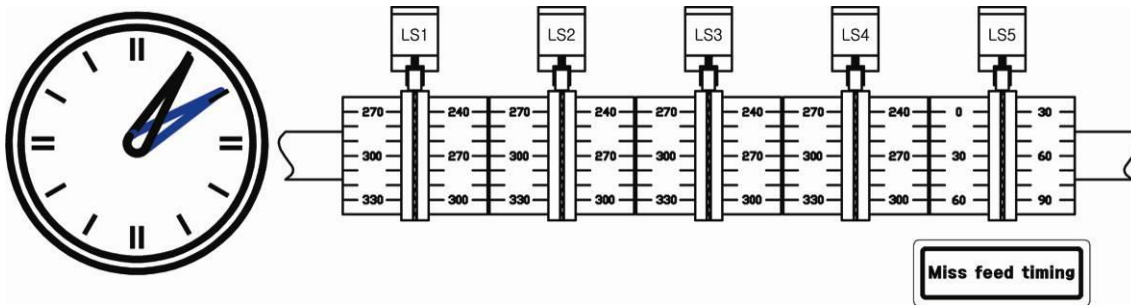

- ① Set selection switch of miss feed and selection switch of pass detection 1 and 2 at OFF in the middle and then dial Press in inching between 1~2 hours.
- ② If you open the cover of Rotary Cam of Press, you will find a switch with miss feeder timing switch attached.

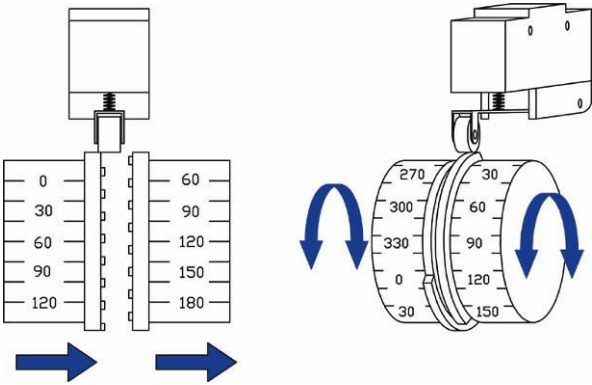

③ Spread and dial the cam below the switch.

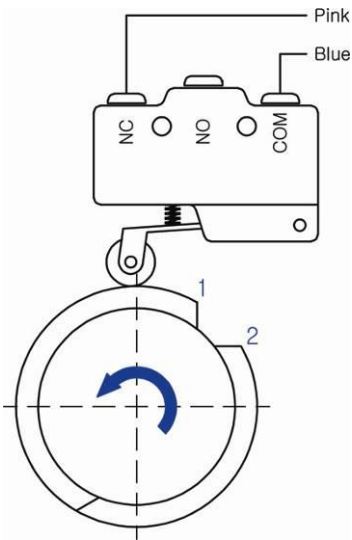

④ Spread the distance between cams so that switch contact point is ON when Press is at 1 hour, and OFF at 2 hours.

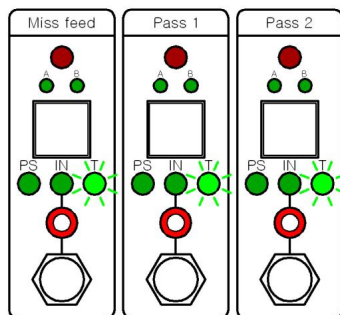
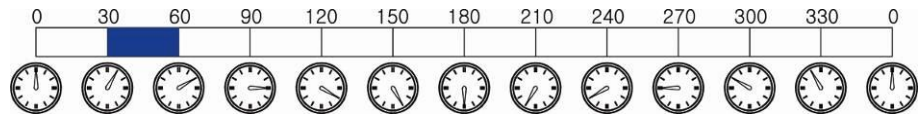

⑤ Normal detection is impossible when timing setting is wrong, so start Press in inching to see if T lamp of PS-300B lights between 1~2 hours.

2) External Proximity Sensor Settings

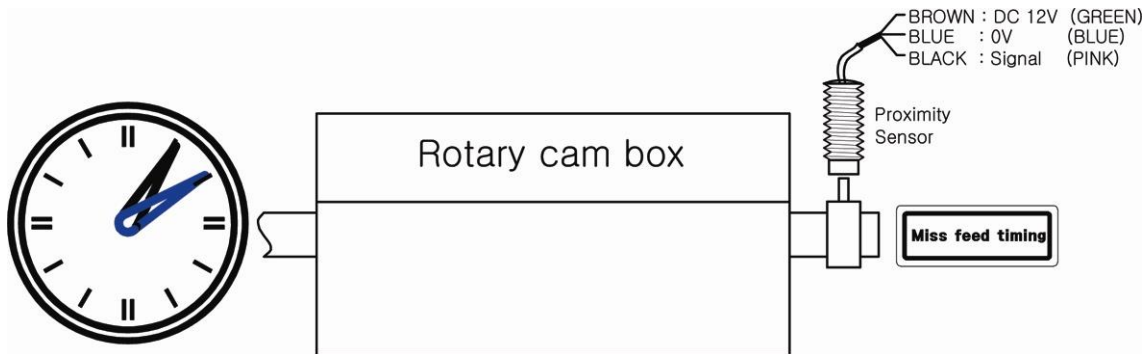

- ① In case that there is no spare switch in Rotary Cam, install Proximity Sensor and Detection Bracket in the axle outside of Rotary Cam box.
- ② Adjust so that Proximity Sensor work, when Press is at 1~2 hours.

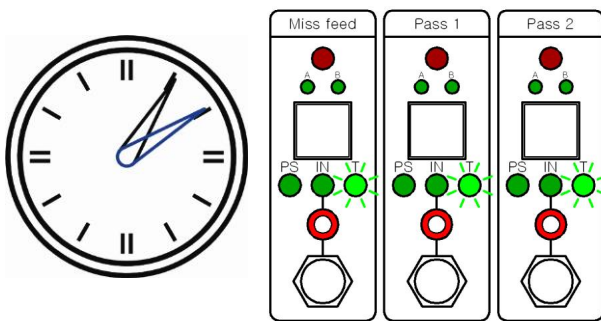

- ③ Normal detection is impossible when timing setting is wrong, so start Press in inching to see if T lamp of PS-300B lights between 1~2 hours.

8. Wiring of Mic Jack Connector

- ◆ Refer to this instructions for wiring light sensor and proximity sensor to Mic Jack Connector at the bottom of PS-300B.

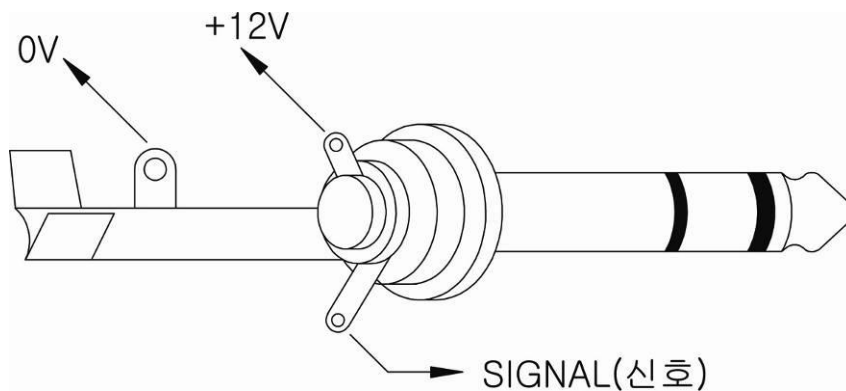
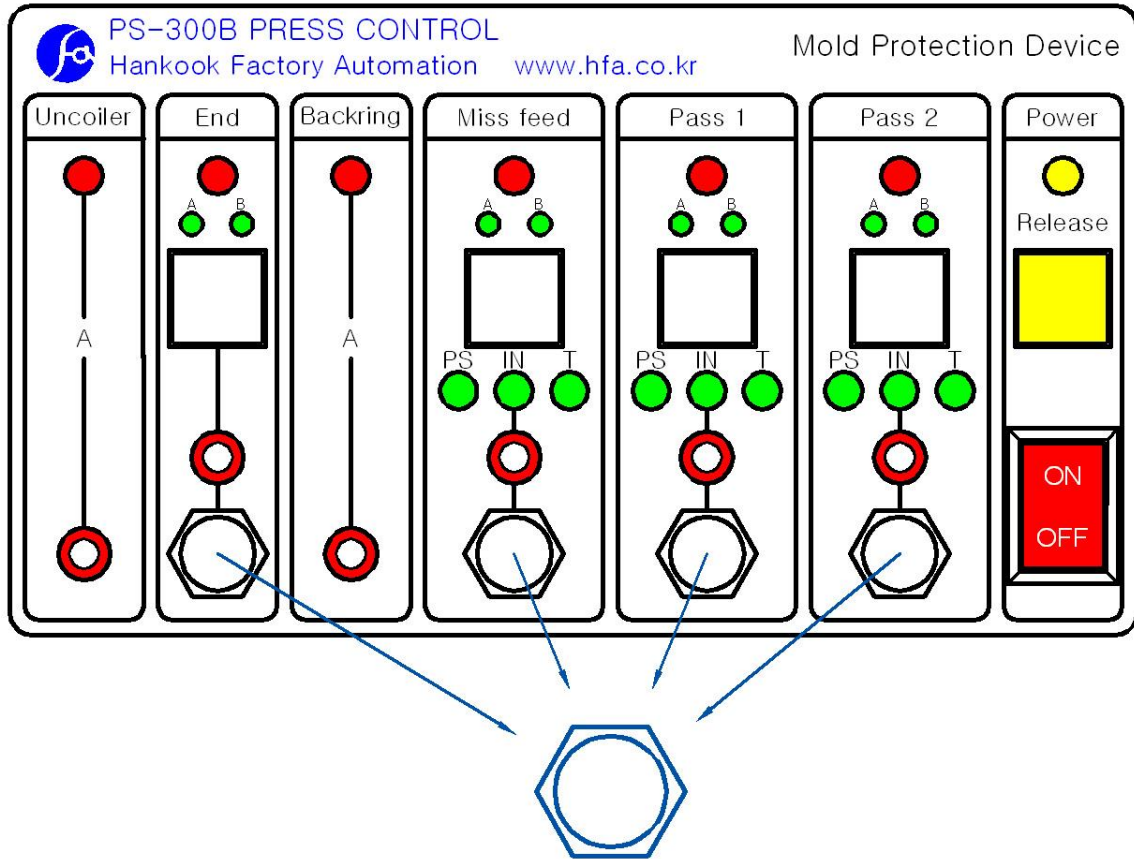

9. PS-300B Wiring Diagram

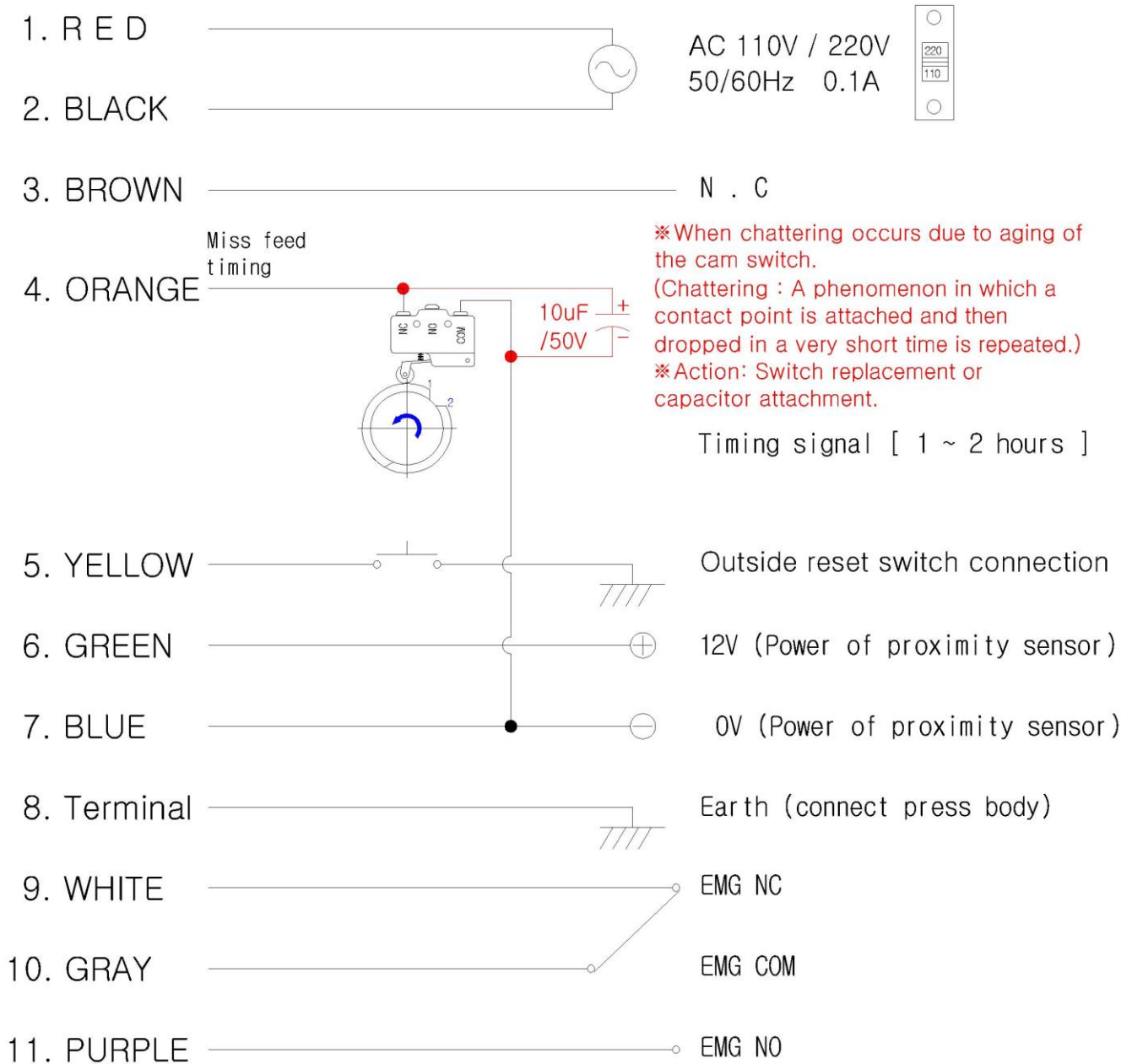

* emergency stop wiring: connect with existing emergency stop switch in series.

